

## Main disconnecter, base-mounted, ŁK25RG B08

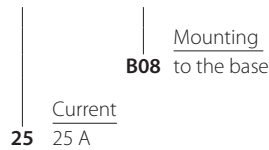

### Ordering code

**ŁK 25 RG\ B08**



Standard assemblies are fitted with a switch 2.421

### Dimensions

Base mounting

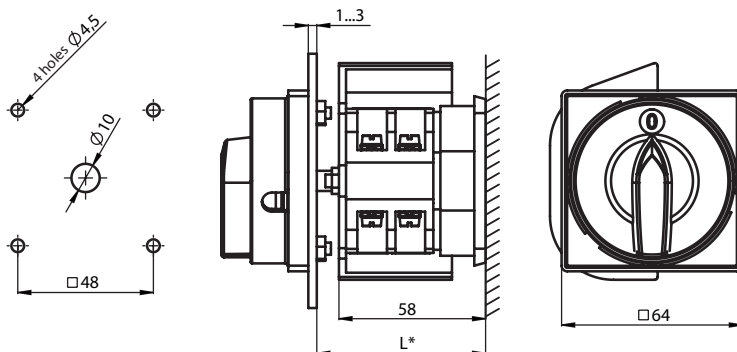

\* L - box depth (should be specified in the order)

### Technical data (continuous work)

Rated insulation voltage $U_i$	690 V
Rated withstand impulse voltage $U_{imp}$	6 kV
Rated continuous current $I_U=I_{th}$	25 A
Rated operational power $P_e$ for AC-3	7 kW (230 V) 13 kW (400 V) 14 kW (500 V) 14 kW (690 V)
Rated operational power $P_e$ for AC-4	6 kW (230 V) 8 kW (400 V) 8 kW (500 V) 7 kW (690 V)
Rated operational current $I_e$ for AC-3	25 A (230 V) 25 A (400 V) 22 A (500 V) 14 A (690 V)
Rated operational current $I_e$ for AC-4	20 A (230 V) 16 A (400 V) 12 A (500 V) 8 A (690 V)
Rated operational current $I_e$ for DC-1	8 A (110 V) 2.5 A (220 V)
Rated operational current $I_e$ for DC-21	12 A (110 V) 3 A (220 V)
Short-time short-circuit withstand current $I_{cw}(1s)$	1 kA
Rated short-circuit making current $I_{cm}$	1.4 kA
Rated conventional short-circuit current	13 kA
Rated current fuse link gG	25 A
Ambient temperature	-40 ... +70°C (work) -40 ... +70°C (storage)
Wire gauge	2.5...6 mm <sup>2</sup>
Protection level: PN-EN 60529 to the panel	IP65
Vibration test (acc. to IEC 60068-2-6)	2...13, 2...100 Hz (frequency) ± 1 mm (acceleration amplitude) ±0.7 g (acceleration amplitude)
Shock test (acc. to IEC 60068-2-27)	15 g (peak acceleration) 11 ms (impulse duration)
Damp heat cyclic test (acc. to IEC 60068-2-30)	55°C (ambient temperature) 95% (relative humidity)
Salt mist cyclic test (acc. to IEC 60068-2-52)	severity 1