

Main disconnecter, base-mounted, ŁK16RG B08

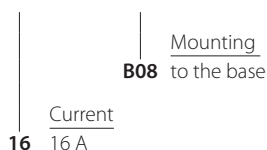

Ordering code

ŁK 16 RG\ B08



Standard assemblies are fitted with a switch 2.421

Dimensions

Base mounting

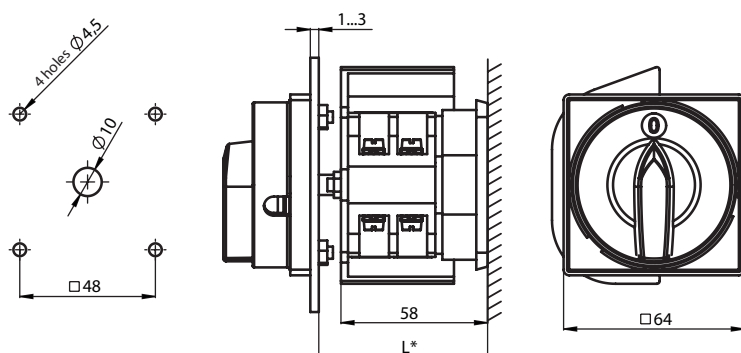

* L - box depth (should be specified in the order)

Technical data (continuous work)

Rated insulation voltage U_i	690 V
Rated withstand impulse voltage U_{imp}	6 kV
Rated continuous current $I_U=I_{th}$	16 A
Rated operational power P_e for AC-3	5 kW (230 V) 8 kW (400 V) 10 kW (500 V) 11 kW (690 V)
Rated operational power P_e for AC-4	5 kW (230 V) 7 kW (400 V) 7 kW (500 V) 6 kW (690 V)
Rated operational current I_e for AC-3	16 A (230 V) 16 A (400 V) 16 A (500 V) 12 A (690 V)
Rated operational current I_e for AC-4	16 A (230 V) 13 A (400 V) 10 A (500 V) 7 A (690 V)
Rated operational current I_e for DC-1	8 A (110 V) 2.5 A (220 V)
Rated operational current I_e for DC-21	10 A (110 V) 3 A (220 V)
Short-time short-circuit withstand current $I_{cw}(1s)$	0.9 kA
Rated short-circuit making current I_{cm}	1.3 kA
Rated conventional short-circuit current	13 kA
Rated current fuse link gG	16 A
Ambient temperature	-40 ... +70°C (work) -40 ... +70°C (storage)
Wire gauge	1.5...4 mm ²
Protection level: PN-EN 60529 to the panel	IP65
Vibration test (acc. to IEC 60068-2-6)	2...13, 2...100 Hz (frequency) ± 1 mm (acceleration amplitude) ±0.7 g (acceleration amplitude)
Shock test (acc. to IEC 60068-2-27)	15 g (peak acceleration) 11 ms (impulse duration)
Damp heat cyclic test (acc. to IEC 60068-2-30)	55°C (ambient temperature) 95% (relative humidity)
Salt mist cyclic test (acc. to IEC 60068-2-52)	severity 1