

## Cam switch, panel-mounted, ŁK25R P

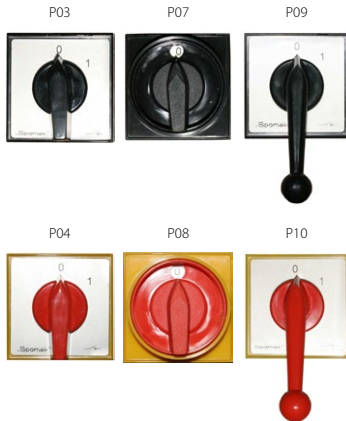

### Ordering code

ŁK 25 R-  \

#### Mounting

- P01** with legend plate and knob IP41
- P02** yellow legend plate, red knob IP41
- P03** front I (IP65)
- P04** front I yellow-red (IP65)
- P07** front III (IP65), lockable
- P08** front III yellow-red (IP65), lockable
- P09** front II (IP65), long black knob
- P10** front II (IP65), long knob, yellow-red

#### Assembly number

- 1.825** Disconnecter 0-1 (1 - pole)
- 1.828** Disconnecter 0-1 (2 - pole)
- 2.8211** Disconnecter 0-1 (3 - pole)
- 2.8210** Disconnecter 0-1 (4 - pole)
- 3.8220** Disconnecter 0-1 (5 - pole)
- 3.8210** Disconnecter 0-1 (6 - pole)
- 4.8240** Disconnecter 0-1 (7 - pole)
- 4.824** Disconnecter 0-1 (8 - pole)
- 5.8220** Disconnecter 0-1 (9 - pole)
- 5.822** Disconnecter 0-1 (10 - pole)
- 6.8210** Disconnecter 0-1 (11 - pole)
- 6.821** Disconnecter 0-1 (12 - pole)
- 7.8220** Disconnecter 0-1 (13 - pole)
- 7.822** Disconnecter 0-1 (14 - pole)
- 8.8270** Disconnecter 0-1 (15 - pole)
- 8.827** Disconnecter 0-1 (16 - pole)
- 9.8210** Disconnecter 0-1 (17 - pole)
- 9.821** Disconnecter 0-1 (18 - pole)
- 10.8210** Disconnecter 0-1 (19 - pole)
- 10.821** Disconnecter 0-1 (20 - pole)
- 3.8368** Reversing switch L-0-P
- 3.83139** 2-speed switch  
2 separate windings
- 4.8390** 2-speed Dahlander switch
- 7.8538** 2-speed reversing  
Dahlander switch
- 4.831** 3-phase starting switch 0-Y-Δ
- 5.8538** 3-phase starting  
reversing switch
- 6.4470** 3-speed Dahlander switch  
single winding for low speed
- 6.4480** 3-speed Dahlander switch  
single winding for medium speed
- 6.4490** 3-speed Dahlander switch  
single winding for high speed
- 4.883** Voltmeter selector switch
- 2.4414** Rotary disconnecter 0-1
- 2.8445** Control switch 0-1-2-3
- 1.834** Disconnecter 1-0-2 (1 - pole)
- 2.8338** Disconnecter 1-0-2 (2 - pole)
- 3.8380** Disconnecter 1-0-2 (3 - pole)
- 4.8396** Disconnecter 1-0-2 (4 - pole)
- 5.8380** Disconnecter 1-0-2 (5 - pole)
- 6.8380** Disconnecter 1-0-2 (6 - pole)
- 7.8380** Disconnecter 1-0-2 (7 - pole)
- 8.8380** Disconnecter 1-0-2 (8 - pole)
- 9.8380** Disconnecter 1-0-2 (9 - pole)
- 10.8380** Disconnecter 1-0-2 (10 - pole)

Current

25 25 A

### Components

#### Fronts of cam switches

Front I ŁK-1406

Front II ŁK-1407

Front III ŁK-1408 (padlockable)

## Dimensions

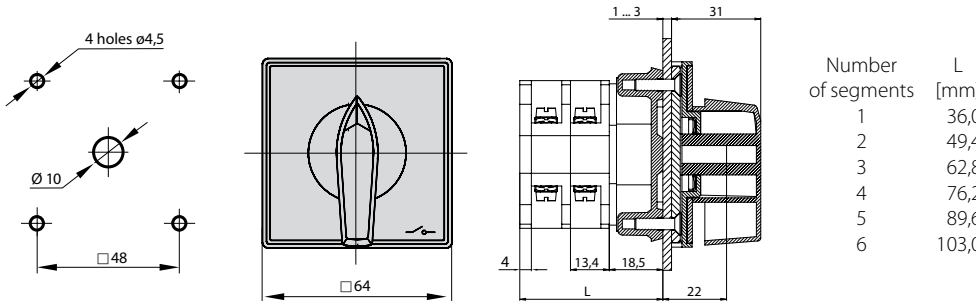

\* It is possible to increase the length by a multiple of 13.4 [mm]

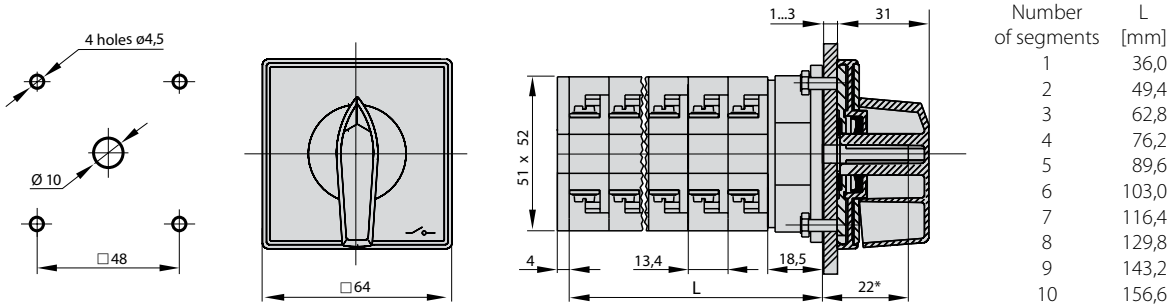

\* It is possible to increase the length by a multiple of 13.4 [mm]

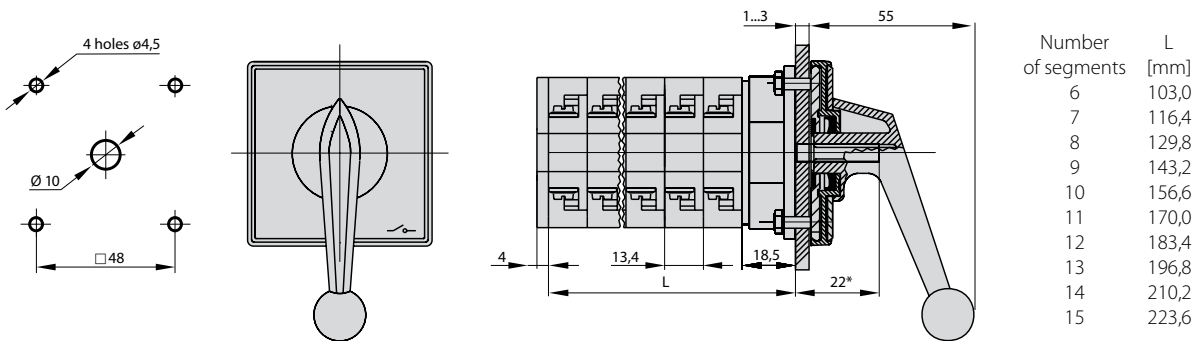

\* It is possible to increase the length by a multiple of 13.4 [mm]

## Number of segments in the switch

1 ... 15

**Technical data (continuous work)**

Rated insulation voltage $U_i$	690 V
Rated withstand impulse voltage $U_{imp}$	6 kV
Rated continuous current $I_u=I_{th}$	25 A
Rated operational power $P_e$ for AC-3	7 kW (230 V) 13 kW (400 V) 14 kW (500 V) 14 kW (690 V)
Rated operational power $P_e$ for AC-4	6 kW (230 V) 8 kW (400 V) 8 kW (500 V) 7 kW (690 V)
Rated operational current $I_e$ for AC-3	25 A (230 V) 25 A (400 V) 22 A (500 V) 14 A (690 V)
Rated operational current $I_e$ for AC-4	20 A (230 V) 16 A (400 V) 12 A (500 V) 8 A (690 V)
Rated operational current $I_e$ for DC-1	8 A (110 V) 2.5 A (220 V)
Rated operational current $I_e$ for DC-21	12 A (110 V) 3 A (220 V)
Short-time short-circuit withstand current $I_{cw}(1s)$	1 kA
Rated short-circuit making current $I_{cm}$	1.4 kA
Rated conventional short-circuit current	13 kA
Rated current fuse link gG	25 A
Tightening torque, terminals	1.2 Nm
Mechanical endurance	3.0 mln (transposition cycles)
Ambient temperature	-40 ... +70°C (work) -40 ... +70°C (storage)
Wire gauge	2.5...6 mm <sup>2</sup>
Protection level: PN-EN 60529 to the panel	IP65
Vibration test (acc. to IEC 60068-2-6)	2...13, 2...100 Hz (frequency) ± 1 mm (acceleration amplitude) ±0.7 g (acceleration amplitude)
Shock test (acc. to IEC 60068-2-27)	15 g (peak acceleration) 11 ms (impulse duration)
Damp heat cyclic test (acc. to IEC 60068-2-30)	55°C (ambient temperature) 95% (relative humidity)
Salt mist cyclic test (acc. to IEC 60068-2-52)	severity 1